

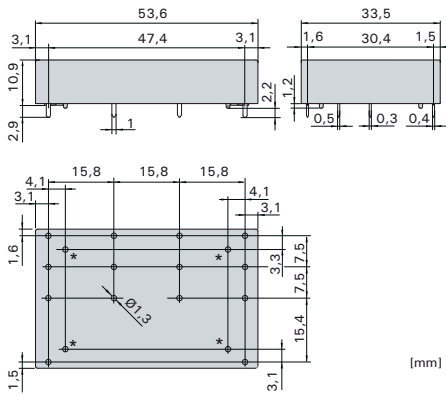

Relay data

- PCB relay with forcibly guided contacts
- Protective separation between coil and contacts (> 5.5 mm) and contacts side by side (> 5.5 mm)
- EN 50205 type A
- Double and reinforced insulation
- SMD arrangement below relay possible
- Contact mounting: SIF422 4NO/2NC
- Compact height: only 10.9mm
- Mean coil power 0.66W
- Holding power 0.20 W
- For Railway Applications EN50155



* Do not drill when SMD arrangement.

Contact material	AgCuNi + 0.2 µm Au
Type of contact	Single contact with notched crown
Rated switching capacity	250VAC 8A AC1 2'000VA
Electr. life AC1 (360 S/h)	approx. 100'000
Inrush current max.	30A for 20ms
Switching voltage range	5 to 250VDC/VAC
Switching current range*	5mA to 8A
Switching capacity range*	60mW to 2'000W (VA)
Contact resistance (as delivered)	≤ 100mΩ / 28 V / 100mA

* Guide values

Standard coils for direct current (other voltages on request)

Nominal voltage VDC	Min. pick-up voltage at 20°C VDC	Drop-out voltage at 20°C VDC	Nominal current in mA	Resistance in Ohm at 20°C	Tolerance in %
5	≤ 3.5	≥ 0.5	133.3	37.5	± 10
12	≤ 8.4	≥ 1.2	55.8	215	± 10
18	≤ 12.6	≥ 1.8	38.9	462	± 10
20	≤ 14.0	≥ 2.0	33.3	600	± 10
24	≤ 16.8	≥ 2.4	27.5	870	± 10
48	≤ 33.6	≥ 4.8	13.8	3'460	± 10
60	≤ 42.0	≥ 6.0	11.1	5'400	± 13
110	≤ 77.0	≥ 11.0	6.0	18'300	± 15

Ordering example

SIF 4 2 2 24VDC

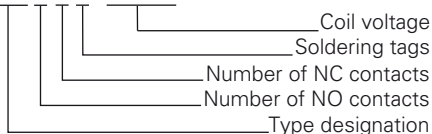

General data

Circuit diagram (view on relay upper side)

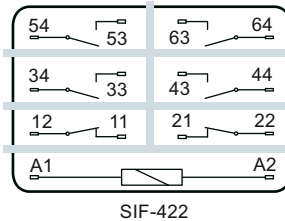

Double or reinforced insulation

Mechanical life	> 10 x 10 ⁶ operations
Switching frequency, mechanical	15Hz
Response time	typically 20ms
Drop-out time**	typically 8ms
Bounce time of NO contact	typically 3ms
Bounce time of NC contact	typically 12ms
Shock resistance	NO contact 10g NC contact 6g
Vibration resistance	NO contact 10g NC contact 2g
Test voltage coil to contacts	4'000Veff 1min
Test voltage contacts against each other	4'000Veff 1min
Test voltage contact open	1'500Veff 1min
Insulation resistance at Up 500V	10 ⁸ Ω
Creepage resistance	CTI 175
Weight	approx. 35g
Mounting position	any
Ambient temperature	-40°C to +70°C
Type of protection	RT II
Solder bath temperature	270°C/5s
Thermal resistance	47K/W
Temperature limit for coil	120°C
Pollution degree	2
Oversvoltage category	III
Resistance to short circuiting	1'000A SCPD 10A gL/gG (pre-fuse)

** without spark suppression

Insulation terms

Double or reinforced insulation >5.5mm between all current circuits

Tests, regulations

Approvals	SEV, UL, cUL, TÜV
UL File E188953	Sec. 6
Insulation class IEC 60664-1	250VAC
Protection class II	VDE 0106
Fire protection requirements	UL 94 / V0

Diagrams

Contact lifetime

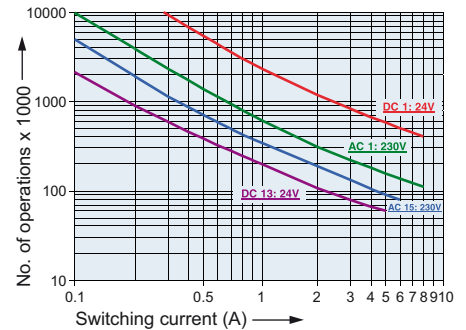

Max. switching characteristics (DIN EN 60947-4-1/ EN 60947-5-1):

- AC 1: 250V/8A
- AC 15: 230V/6A
- DC 1: 24V/8A
- DC 13: 24V/5A/0.1Hz
- UL508: B300/R300
- Maximal contact load at AC 1 with 230V:
 - 2 contacts each with 8A
 - 3 contacts each with 6A
 - 4 contacts each with 4.5A

Load limit curve with direct current (Resistive load)

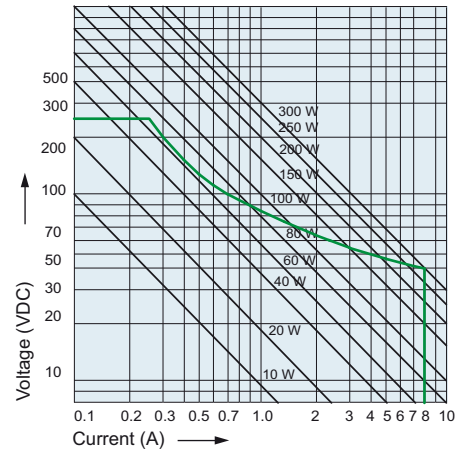

Excitation voltage range

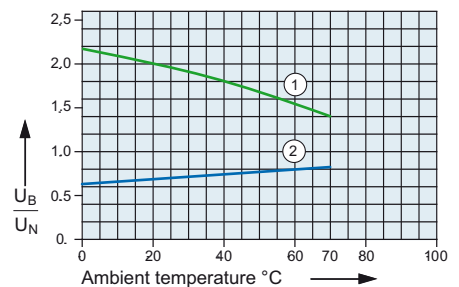

- 1) Max. excitation voltage with contact load ≤ 6A
- 2) Min. excitation voltage (guaranteed values) without previous operation

No heat accumulation due to intrinsic heating of other components.
Continuous duty 100%.