

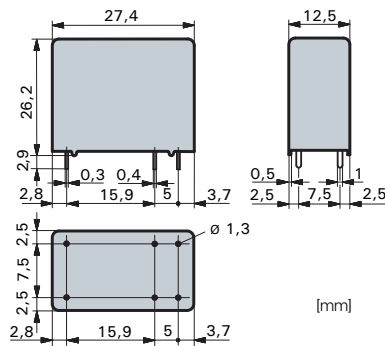

Relay data

- PCB relay with forcibly guided contacts
- Protective separation between coil and contacts (leakage and creepage distances > 14mm); protective separation between left and right contact side (leakage and creeping distances > 5.5mm)
- EN 50205, type A
- Contact mounting: SIM112 1NO/1NC
- Small external dimensions
- Mean coil power 0.5W
- Holding power 0.15 W



Contact material	AgSnO ₂ +0.2µm Au
Type of contact	Crest contact
Rated switching capacity	250VAC 8A AC1 2'000VA
Electr. life AC1 (360 cycles/h)	approx. 100'000
Inrush current max.	20A for 20ms
Switching voltage range	5 to 250 VDC/VAC
Switching current range*	10mA to 8A
Switching capacity range*	0.06VA(W) to 2'000VA
Contact resistance (as delivered)	≤100mΩ/28V/100mA

* Guide values

Standard coils for direct current (other voltages on request)

Nominal voltage VDC	Min. pick-up voltage at 20°C	Drop-out voltage at 20 °C	Nominal current in mA	Resistance in Ohm at 20 °C	Tolerance in %
5	3,5	≥ 0,5	111,0	45	± 10
6	4,2	≥ 0,6	85,7	70	± 10
12	8,4	≥ 1,2	44,4	270	± 10
21	14,7	≥ 2,1	23,8	880	± 10
24	16,8	≥ 2,4	21,8	1'100	± 10
48	33,6	≥ 4,8	10,9	4'400	± 13
60	42,0	≥ 6,0	8,7	6'850	± 15
110	77,0	≥ 11,0	5,5	20'000	± 15

Ordering example

SIM 1 1 2 24VDC

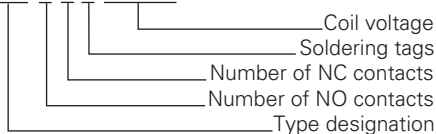

General data

Circuit diagram (view on relay upper side)

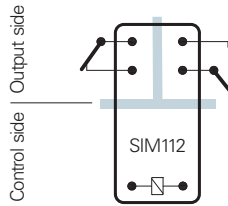

Double or reinforced insulation

Mechanical life	> 10 x 10 ⁶ operations
Switching frequency, mechanical	15Hz
Response time	typically 10ms
Drop-out time**	typically 3ms
Bounce time of NO contact	typically 6ms
Bounce time of NC contact	typically 12ms
Shock resistance 16ms	NO contact > 10g
Vibration resistance 10-200Hz	NO contact > 10g
Test voltage coil/contacts	5'000Veff 1min
Test voltage left to right contact sides	4'000Veff 1min
Test voltage contact open	1'500Veff 1min
Insulation resistance	10 ¹¹ Ω
Creepage resistance	CTI 250
Weight	approx. 20g
Mounting position	any
Ambient temperature	-40°C to +70°C
Type of protection	RT II
Solder bath temperature	270 °C/5s
Thermal resistance	55K/W
Temperature limit for coil	120°C
Pollution degree	2
Overvoltage category	III
Resistance to short circuiting	1'000A SCPD 10A gG (pre-fuse)

** without spark suppression

Insulation terms

Coil/contacts:
Double or reinforced insulation > 14mm
Left to right contact side:
Double or reinforced insulation > 5.5mm

Tests, regulations

Approvals	SEV, UL, cUL, TÜV
UL File E188953	Sec. 3
Insulation class IEC 60664-1	250VAC
Protection class II	VDE 0106
Fire protection requirements	UL 94 / V0

Diagrams

Contact lifetime for NO contact

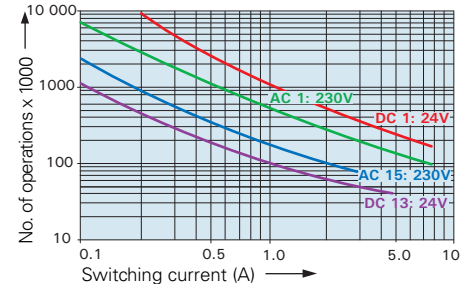

Max. switching characteristics (determined acc. to DIN EN 60947-5-1 table C2):
AC 15: 230V/3A
DC 13: 24V/4A
DC 13: 24V/6A/0,1Hz
UL 508: C150/R300

Load limit curve with direct current

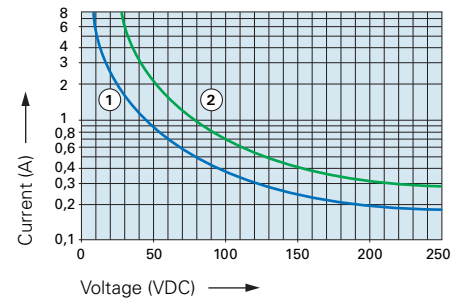

- 1) Inductive load, L/R 40 ms
- 2) Resistive load

Excitation voltage range

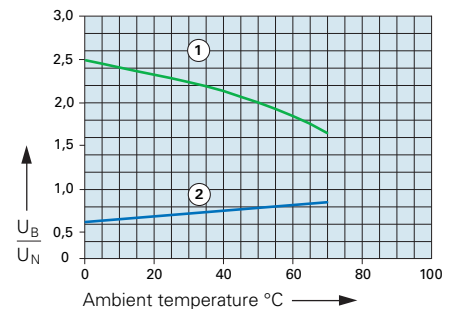

- 1) Max. excitation voltage with contact load ≤ 2A
- 2) Min. excitation voltage (guaranteed values) without previous operation

No heat accumulation due to intrinsic heating of other components.
Continuous duty 100%.