

## Relay data

- PCB relay with forcibly guided contacts
- Protective separation between coil/control contacts and output contacts (> 10mm) and output contacts side by side (> 8mm)
- EN 50205, type A
- Contact mounting:
  - SIR312P „Power“ Control contacts 1NO/1NC
  - Output contacts 2NO
  - SIR222P „Power“ Control contacts 2NC
  - Output contacts 2NO
- Inrush current 60A / continuous current 12A
- Mean coil power 0.75W
- Holding power 0.23 W

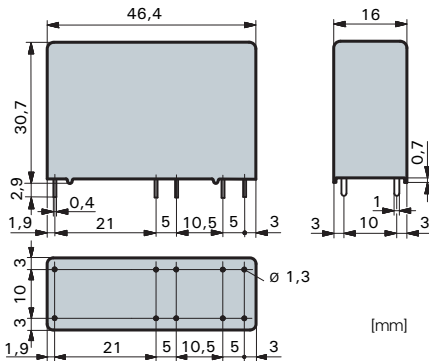

### Control Contacts

Contact material	AgSnO <sub>2</sub> +0.2µm Au
Rated switching capacity 250VAC 6A AC1 1'500VA	
Electr. life AC1 (360 cycles/h)	approx. 100'000
Inrush current max.	15A for 20ms
Switching voltage range	5 to 250 VDC/VAC
Switching current range*	5mA to 6A
Switching capacity range* 60mW to 1'500W (VA)	
Contact resistance (as delivered)	≤100mΩ/28V/100mA

\* Guide values

### Output contacts

Contact material	AgSnO <sub>2</sub>
Rated switching capacity 250VAC (440VAC)	
12A AC1 3'000VA	
Electr. life AC1 (360 cycles/h)	approx. 250'000
Inrush current max.	60A for 20ms
Switching voltage range	5 to 480 VDC/VAC
Switching current range*	10mA to 12A
Switching capacity range* 120mW to 3'000W (VA)	
Contact resistance (as delivered)	≤100mΩ/28V/100mA

\* Guide values

### Standard coils for direct current (examples) other voltages on request

Nominal voltage VDC	Min. pick-up voltage at 20°C VDC	Drop-out voltage at 20°C VDC	Nominal current in mA	Resistance in Ohm at 20 °C	Tolerance in %
5	≤ 3.5	≥ 0.5	151.0	33	± 10
12	≤ 8.4	≥ 1.2	63.1	190	± 10
18	≤ 12.6	≥ 1.8	41.6	432	± 10
20	≤ 14.0	≥ 2.0	37.7	530	± 10
24	≤ 16.8	≥ 2.4	31.5	760	± 10
48	≤ 33.6	≥ 4.8	15.7	3'050	± 10
60	≤ 42.0	≥ 6.0	12.5	4'800	± 10
110	≤ 77.0	≥ 11.0	6.8	16'000	± 15

## General data

### Circuit diagram (view on relay upper side)

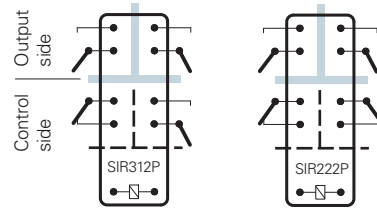

--- Basic insulation  
 — Double or reinforced insulation

Mechanical life	> 10 x 10 <sup>6</sup> operations
Switching frequency, mechanical	15Hz
Response time	typically 15ms
Drop-out time**	typically 4ms
Bounce time of NO contact	typically 6ms
Bounce time of NC contact	typically 12ms
Shock resistance 16ms	NO contact 17g NC contact 7g
Vibration resistance 10-200Hz	NO contact 10g NC contact 4,5g

Test voltage coil/control contacts	2'500Veff 1min
Test voltage coil-control contacts/output contacts	5'000Veff 1min
Test voltage output contacts as against each other	4'000Veff 1min
Test voltage contact open	1'500Veff 1min
Insulation resistance	10 <sup>11</sup> Ω
Creepage resistance	CTI 250
Weight	approx. 32g
Mounting position	any
Ambient temperature	-40°C to +70°C
Type of protection	RT II
Solder bath temperature	270 °C/5s
Thermal resistance	55K/W
Temperature limit for coil	120°C
Pollution degree	2
Overvoltage category	III
Resistance to short circuiting 1'000A SCPD 6A control contacts	gG (pre-fuse)
Resistance to short circuiting 1'000A SCPD 16A output contacts	gL/gG (pre-fuse)

Test voltage output contacts as against each other	4'000Veff 1min
Test voltage contact open	1'500Veff 1min
Insulation resistance	10 <sup>11</sup> Ω
Creepage resistance	CTI 250
Weight	approx. 32g
Mounting position	any
Ambient temperature	-40°C to +70°C
Type of protection	RT II
Solder bath temperature	270 °C/5s
Thermal resistance	55K/W
Temperature limit for coil	120°C
Pollution degree	2
Overvoltage category	III
Resistance to short circuiting 1'000A SCPD 6A control contacts	gG (pre-fuse)
Resistance to short circuiting 1'000A SCPD 16A output contacts	gL/gG (pre-fuse)

\*\* without spark suppression

### Insulation terms

Coil to control contacts:	Basic insulation
Coil/control contacts to output contacts:	Double or reinforced insulation
Double or reinforced insulation	> 10mm
Output contacts as against each other:	Double or reinforced insulation > 8mm

### Tests, regulations

Approvals	SEV, UL, cUL, TÜV
UL File E188953	Sec. 3
Insulation class IEC 60664-1	250VAC
Protection class II	VDE 0106
Fire protection requirements	UL 94 / V0

### Options, accessories

PCB socket:	see page 31
-------------	-------------

## Diagrams

### contacts each with (output contacts)

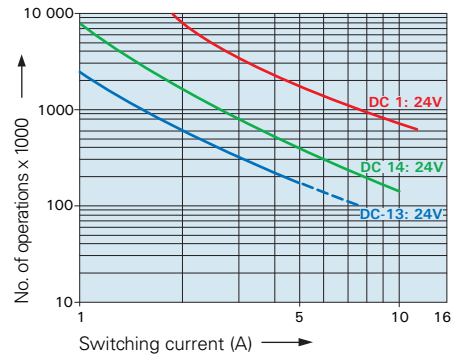

### Contact lifetime (output contacts)

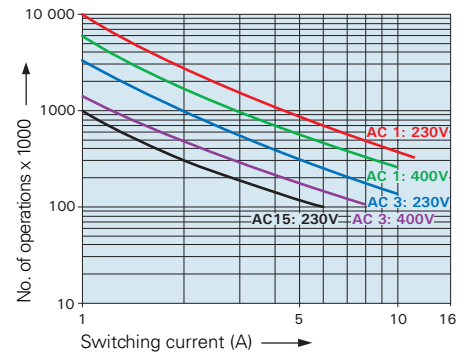

Maximal contact load at AC 1 with 230V:  
2 contacts each with 12A

### Excitation voltage range

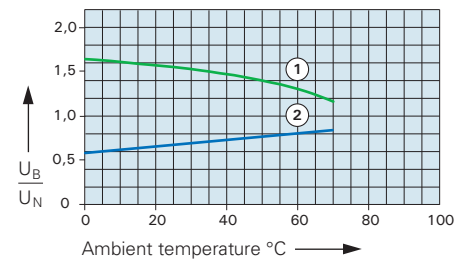

- 1) Max. excitation voltage with contact load ≤ 2A control contacts / ≤ 10A output contacts
- 2) Min. excitation voltage (guaranteed values) without previous operation

No heat accumulation due to intrinsic heating of other components.  
Continuous duty 100%.

### Ordering example

SIR 3 1 2 P 24VDC

