

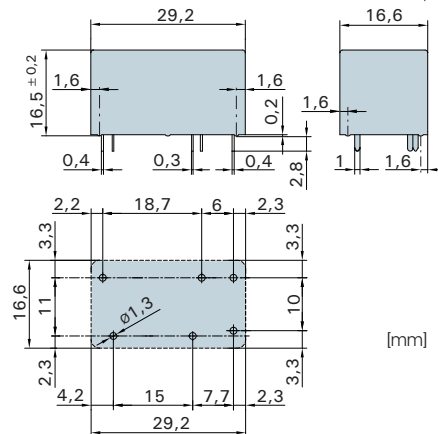

## Relay data

- PCB relay with forcibly guided contacts
- Protective separation between control and load circuit (leakage and creepage distances > 10mm)
- EN 50205, type A
- Double and reinforced insulation between the contacts
- Contact mounting: SIS112 1NO/1NC
- Small external dimensions
- Mean coil power 0.27W
- Holding power 0.08 W
- for Railway Applications: EN 50155



Contact material	AgCuNi+0,2-0,4µm Au
Type of contact	Single contact with notched crown
Rated switching capacity	250VAC 6A AC1 1'500VA
Electr. life AC1 (360 cycles/h)	approx. 100'000
Inrush current max.	30A for 20ms
Switching voltage range	5 to 250VDC/VAC
Switching current range*	5mA to 6A
Switching capacity range*	60mW to 1'500W (VA)
Contact resistance (as delivered)	≤100mΩ/28V/100 mA

\* Guide values

### Standard coils for direct current (other voltages on request)

Nominal voltage VDC	Min. pick-up voltage at 20°C	Drop-out voltage at 20°C	Nominal current in mA	Resistance in Ohm at 20 °C	Tolerance in %
5	≤ 3,5	≥ 0,5	54,9	91	± 10
6	≤ 4,2	≥ 0,6	46,1	130	± 10
9	≤ 6,3	≥ 0,9	30,5	295	± 10
12	≤ 8,4	≥ 1,2	23,0	520	± 10
18	≤ 12,6	≥ 1,8	15,2	1'180	± 10
24	≤ 16,8	≥ 2,4	11,4	2'100	± 10
48	≤ 33,6	≥ 4,8	5,7	8'350	± 13
60	≤ 42,0	≥ 6,0	4,5	13'100	± 15

### Ordering example

SIS 1 1 2 24VDC

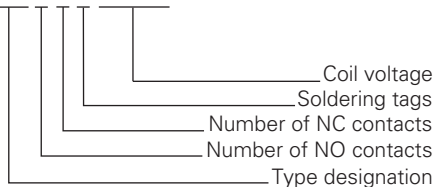

## General data

### Circuit diagram (view on relay upper side)

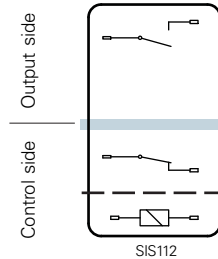

- - - Basic insulation
- ▬ Double or reinforced insulation

Mechanical life	> 10 x 10 <sup>6</sup> operations
Switching frequency, mechanical	15Hz
Response time (NO closed)	typically 10ms
Drop-out time** (NC closed)	typically 3ms
Bounce time of NO contact	typically 2ms
Bounce time of NC contact	typically 15ms
Shock resistance 16ms	NO contact 17g NC contact 7g
Vibration resistance 10-200Hz	NO contact 7g NC contact 2g
Test voltage coil/control contact	2'500Veff 1min
Test voltage coil/control contact/output contact	5'000Veff 1min
Test voltage contact open	1'500Veff 1min
Insulation resistance at Up 500V	10 <sup>8</sup> Ω
Creepage resistance	CTI 175
Weight	approx. 18g
Mounting position	any
Ambient temperature	-40°C to +70°C
Type of protection	RT III
Solder bath temperature	270°C/5s
Thermal resistance	55K/W
Temperature limit for coil	120°C
Pollution degree	2
Overvoltage category	III
Resistance to short circuiting	1'000A SCPD 6A gL/gG (pre-fuse)

\*\* without spark suppression

### Insulation terms

Coil to control contact: Basic insulation  
Coil/control contact to output contact: Double or reinforced insulation > 10mm

### Tests, regulations

Approvals	SEV, UL, cUL, TÜV
UL File E188953	Sec. 5
Insulation class IEC 60664-1	250VAC
Protection class II	VDE 0106
Fire protection requirements	UL 94 / V0

## Diagrams

### Contact lifetime

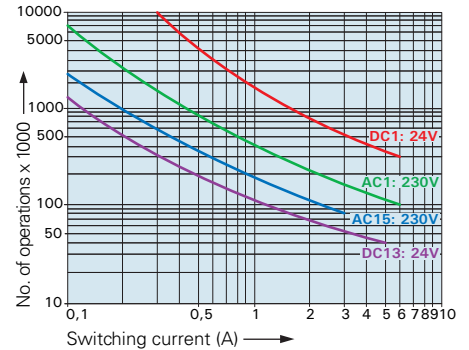

Max. switching characteristics (determined acc. to DIN EN 60947-4-1 / EN 60947-5-1):

- AC 1: 250V/6A
- AC 15: 230V/3A
- DC 1: 24V/6A
- DC 13: 24V/5A/0,1 Hz
- UL 508: B300 / R300

### Load limit curve with direct current

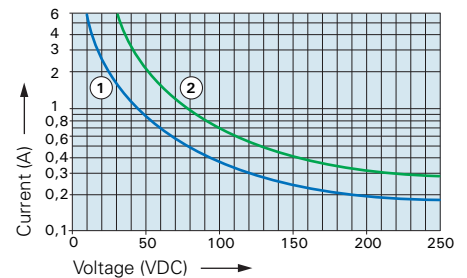

- 1) Inductive load, L/R 40 ms
- 2) Resistive load

### Excitation voltage range

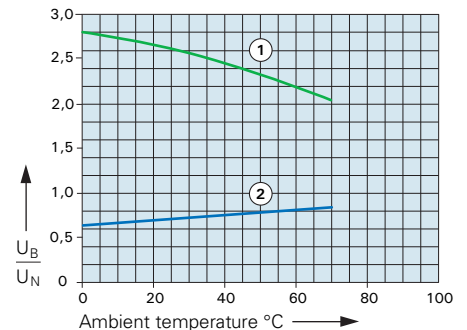

- 1) Max. excitation voltage with contact load ≤ 2A
- 2) Min. excitation voltage (guaranteed values) without previous operation

No heat accumulation due to intrinsic heating of other components.  
Continuous duty 100%.